

Centro Nazionale Multimissione

ASI Workshop Oceansat-2

Rome
June – 25, 2009

Program: Oceansat-2

Event: ASI Workshop

Topic: **Centro Nazionale Multimissione**

Date: 25/06/2009

This document contains proprietary information of ASI, and may not be reproduced, copied, disclosed or utilized in any way, in whole or in part, without the prior written consent of ASI.

Author: L. Garramone

Issue: A

Slide: 1

Table of Contents

- Composition of the Ground Segment
- Composition of the Ground Segment for Oceansat-2
- Main characteristics of the CNM
- Status of the activities
- Capabilities
- Main subsystems
- Subsystems Functional Overview
- CNM for Oceansat-2
- Data processing
- Constraints and drivers

Program: Oceansat-2

Event: ASI Workshop

Topic: **Centro Nazionale Multimissione**

Date: 25/06/2009

This document contains proprietary information of ASI, and may not be reproduced, copied, disclosed or utilized in any way, in whole or in part, without the prior written consent of ASI.

Author: L. Garramone

Issue: A

Slide: 2

Composition of the Ground Segment

- The GS of a space mission may be decomposed, according to the ECSS standards, into three “parts”:

- 1: Subsystem devoted to the control of the satellite;
- 2: Subsystem devoted to the control of the payload;
- 3: Subsystem devoted to the generation of the “mission products”.

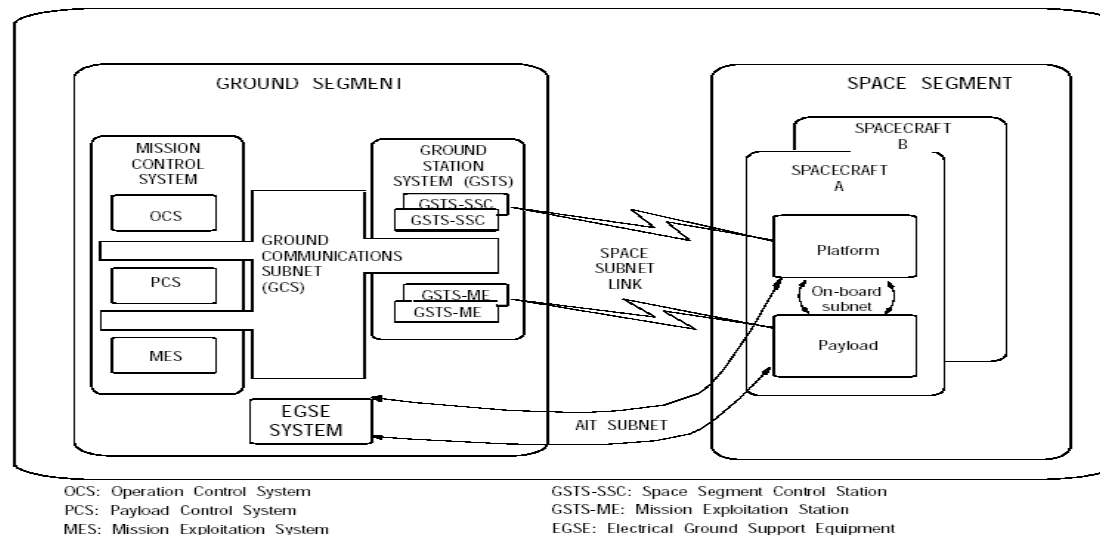

Composition of the Ground Segment for Oceansat-2

MCC: Mission Control Centre
(control of the payload)

SCC : Satellite Control Centre
(control of the spacecraft)

CNM: Centro Nazionale Multimissione
(Italian subsystem devoted to product generation)

SCC and MCC are operated by ISRO; the purpose of this presentation is to give a short description of the CNM.

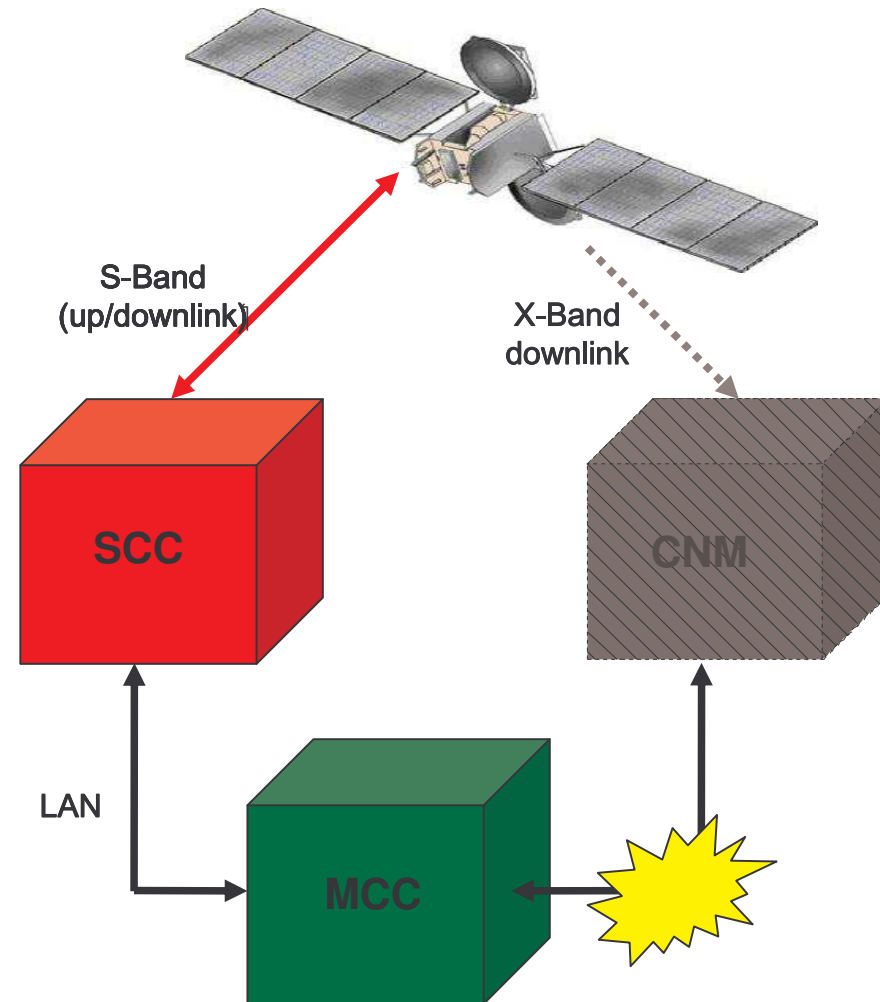

Main characteristics of the CNM

- The Multimission National Center (CNM) is the facility that ASI is developing at the Matera Space Geodesy Center in order to support current and future Earth Observation missions.
- CNM shall be devoted to the reception, demodulation, Direct Ingestion, processing, cataloguing and archiving of data downlinked in X Band by the Earth Observation satellites.
- CNM shall be based on a 6.1 meter antenna developed by ASI.
- CNM is the italian facility devoted to the support of the Oceansat-2 mission.



- In march 2008 ASI signed a contract with Advanced Computer Systems (ACS) for the implementation of the CNM;
- CNM is based on a 6.1 meter antenna, installed at the Matera Space Geodesy Center;
- Activities have a duration of 36 months and are developed through 2 phases of 18 months;
- At the end of phase-1, CNM shall be ready to be operated;
- During the phase-2, CNM shall be capable to operate with reduced functionalities;
- Implementation of the functionalities developed during the phase-2 shall not affect operations;
- Phase-2 shall begin within the current year.

CNM shall be capable to receive and to process data downloaded by the following Earth Observation satellites:

- RADARSAT-1;
- OCEANSAT-2;
- ALOS (only reception and Direct Ingestion);
- ENVISAT;
- AQUA;
- TERRA;
- SAC-D (implementation during the phase-2);

CNM shall catalogue and archive also MSG products;

A data mining tool shall be developed and installed during the phase-2 of the contract.

Main subsystems

- ❑ Antenna (Ant);
- ❑ Reception, Archive & Distribution (RAED);
- ❑ Processing Subsystem (PS);
- ❑ User Interaction Subsystem (UIS).

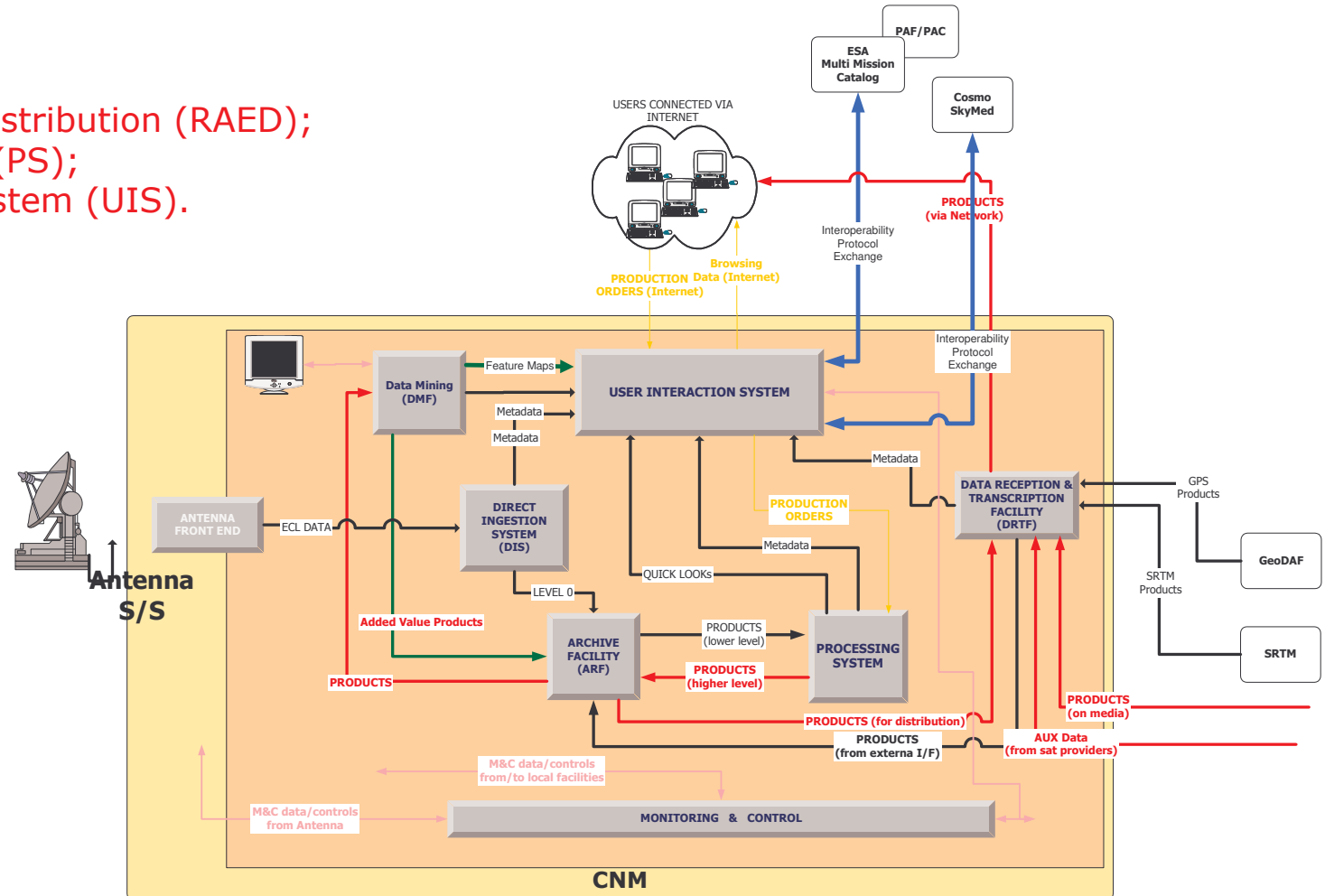

- The **Antenna (ANT)** Subsystem is devoted to track and receive data transmitted by the OT satellites in X-Band;
- The **Reception, Archive and Distribution (RAED)** Subsystem, is in charge of:
 - ❑ Receiving satellite downstream from the antenna and generate raw data.
 - ❑ Receiving data/products from external via media and/or network.
 - ❑ Archive acquired, received and processed data; provide them to the processing system.
 - ❑ Distribute products to end-users (both institutional and private) on media and or network.
 - ❑ Feed the User Interaction Subsystem with inventoried metadata and quick looks.
 - ❑ Implement data mining techniques to define and extract higher level features from EO products.
- The **Processing Subsystem (PS)**, integrates higher level instrument science processors:
 - ❑ Processing Infrastructure (Thin Layer)
 - ❑ Level 0 Processing
 - ❑ Quick Look Processing
 - ❑ Level 1 / Level 2 Processing
- The **User Interaction Subsystem (UIS)**, provides all end-user web-based interfaces for:
 - ❑ Catalogue browsing and navigation
 - ❑ Interoperability services
 - ❑ Product generation/distribution orders management
 - ❑ Help desk
 - ❑ User management
 - ❑ Online Navigation Facility
 - ❑ Data Mining product generation/distribution (e.g. thematic maps)

CNM for Oceansat-2

Oceansat-2 is equipped with three payloads: the Ocean Colour Monitor (OCM), the Scatterometer and the ROSA receiver;

CNM shall be able to receive, Direct Ingest and generate level 0 products for the three payloads:

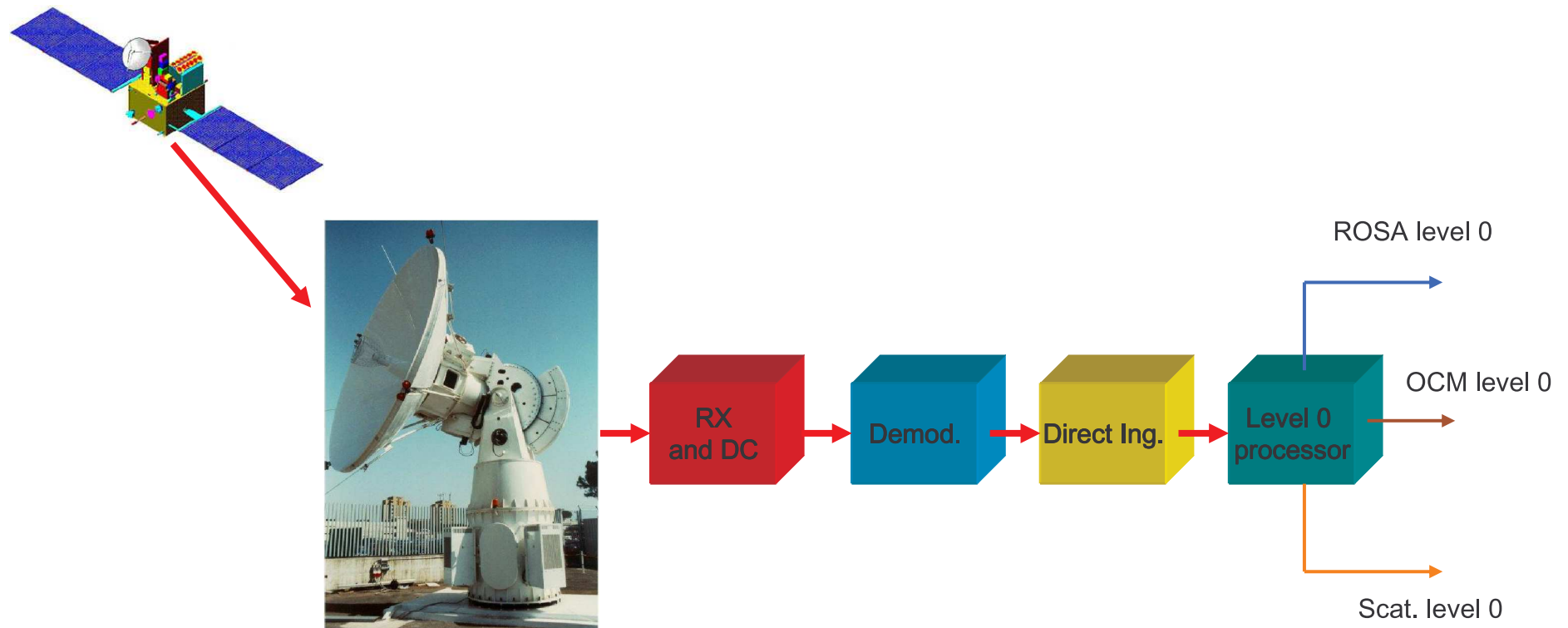

CNM for Oceansat-2: data processing

After the generation of the 0 level products, additional data processing shall be done into the CNM. In particular:

- Level 0 products, coming from OCM the payload, shall be processed and level 1-B products (LAC) shall be distributed and/or archived; Processor shall be furnished by ISRO and shall be integrated into the CNM architecture (through the encapsulator and thin layer mechanisms).
- Level 0 products, coming from the scatterometer, shall be sent to ISRO (via ftp); Processing of these data shall be done by ISRO. Data and products for the scatterometer shall be distributed by ISRO.
- Level 0 products, coming from the ROSA GPS receiver, shall be sent to the relevant processing system (see the dedicated presentation made by F. Vespe).

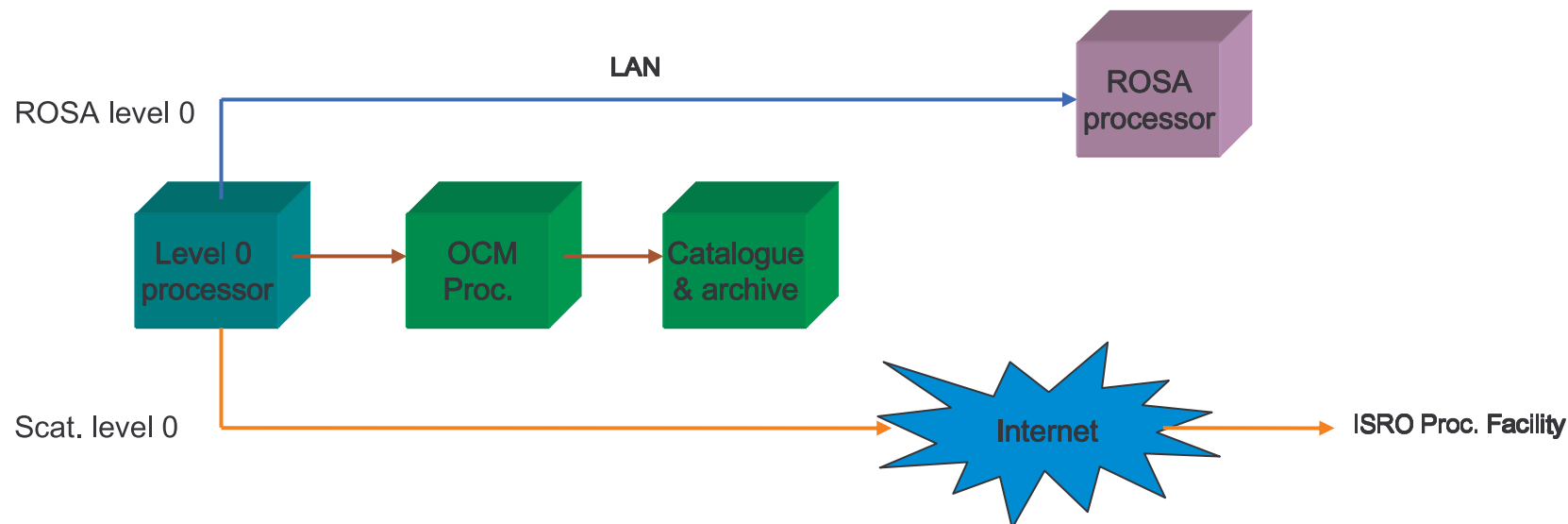

Constraints and drivers

- CNM is a low cost program;
- New developments should be minimized;
- Re-use of existing infrastructures and systems should be maximized;

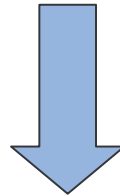

- Generation of Oceansat-2 data and products shall be obtained by means of the CNM. processors shall be not developed. ASI shall integrate into the architecture processors that shall be furnished by ISRO. Integration shall be easy due to the implementation of the thin layer. Oceansat-2 processors shall be seen as black-box.